

## **USB POWER DELIVERY (PD) PROTOCOL AND ITS APPLICATION IN MODERN CONDITIONS**

*The article is devoted to the USB Power Delivery (PD) protocol, its history, features and its capabilities for powering smart devices, as well as a method of powering non-smart devices through the use of PD triggers, as a way to adapt to problems in the energy supply industry of Ukrainian cities.*

**Key words:** *USB, Power Delivery, PD, Voltage, Current, Device, Powering.*

USB Power Delivery (hereafter PD) is a universal fast-charging protocol, or simply a charging protocol, that allows intelligent powering of devices using voltages from 5 to 48 volts and currents of up to 5 amps from a charger [2: 48].

This protocol was first introduced in 2012 as its first version (revision 1.0) by the non-profit organization USB-IF (Implementers Forum), whose task was to provide the ability to charge (power) devices from a USB Type-A (or simply USB-A) port of a charger using a voltage higher than 5 volts and increased current, which was not possible before. The fast-charging protocol known to most people as “Quick Charge” was able to provide a similar function only with its second revision in 2015.

The first version (revision 1.0) of the PD protocol allowed charging (powering) smart gadgets equipped with a USB-A port and supporting this protocol on both the device and charger sides at one of the fixed voltages: 5 V, 12 V, or 20 V, with a maximum current of up to 5 A, but only in the 20 V mode; otherwise, it was limited to 3 A. However, this also depended on the capabilities of the cable used.

Communication between devices was carried out using the VBUS (also known as VCC) wire contact with 24 MHz frequency modulation. This was because the USB connector pinout available in 2012 did not provide dedicated contacts for communication between the charging and charged devices. None of the 9 pins could be properly used to establish a normal handshake between devices, except for the above-mentioned VBUS pin [3: 13].

Despite its convenience and relative intelligence, at that time the PD protocol did not become sufficiently popular and failed to occupy its niche among simple and universal protocols for powering smart devices.

The second version (version 2.0) of the PD protocol aimed to correct this situation. This protocol became an integral part of the new USB connector standard known as Type-C, which was released in 2014 along with the new version of USB 3.0, later renamed USB 3.1 Gen 1. It introduced many innovations. In particular, a dedicated wire contact in the cable was now used for a communication channel between the power source and the consumer, called the Configuration Channel (CC1 and CC2 contacts). It also became possible to identify the type of cable and its power transfer capabilities using a special microcircuit soldered inside the USB-C connector cap. This microcircuit existed before, but its use was not as widespread prior to the introduction of the new version of the PD protocol.

The USB-A pinout of both male and female connectors, specifically for USB 1.0–2.0 and USB 3.0 versions, as well as USB-C, is shown in Figure 1 below, where the wire contacts used for Power Delivery operation (VBUS and CC1/CC2) can be seen:

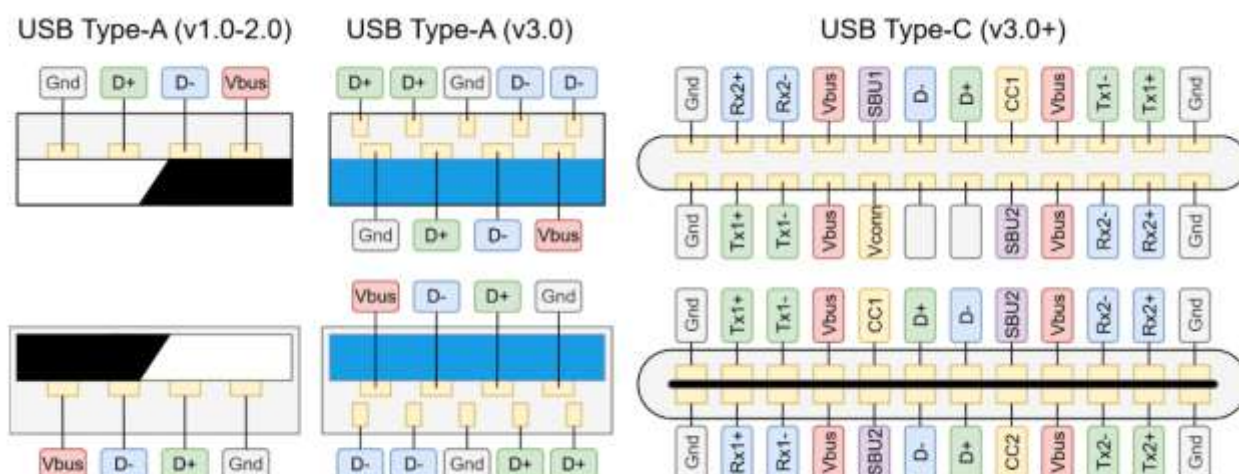

**Picture 1 – USB-A and USB-C pinout of male and female connectors**

With the emergence of the PD charging protocol, a system (protocol) of digital “handshake” between the charged and charging device was properly implemented. The charging process is simply the supply of current, and a complex dialogue between devices, which this system came to coordinate. In particular, this “handshake” is a process consisting of several stages: the first stage is the detection of each other by the devices when connecting a USB-C cable between them; the second stage is the coordination and understanding between the devices of each other's capabilities to establish a safe charging mode; the third final stage is the establishment of a “contract” during which the charging device begins to supply the charged device with the voltage allowed by it in the form of 5 volts, or more, which the charger can provide and which the charged device can consume with the set current [1: 6].

It should also be mentioned that to the set of fixed voltages that was in the first revision of the protocol (5V, 12V, 20V), 9V and 15V were added to expand the range of devices that can be powered and charged via USB-C, while saving the maximum operating current of up to 5 A in 20V mode and 3 A in all other modes.

The latest versions of the PD protocol nowadays are revisions 3.0 and 3.1, which, despite a slight difference in naming, are very different from each other.

Revision 3.0, released in 2019, did not bring with it practically any changes to the main protocol. Instead, a new subprotocol was introduced, which was called PPS (Programmable Power Supply), or PD PPS. This subprotocol as part of PD 3.0 allowed the charging device (consumer) to request not one of the fixed voltages from the charger, but to set it itself within a limited range. This range is from 3.3 to 21V with a step of 20mV and a current step of 50mA to 5A. But this is only possible for chargers that support output with a power of 100W and more. For a charger with an output power of, for example, 65W, the voltage range will be from 3.3 to 11V with a maximum current of 3A [4: 3].

Revision 3.1, released in 2021, in turn, brought more significant changes and improvements. In particular, chargers that have this protocol on board can transmit from 140W to 240W via a single USB-C port. This was made possible by expanding the set of supported voltages to values such as 28V, 36V and 48V while maintaining a maximum current of 5A, which allows one to get up to 140W, 180W and 240W from

the charger when using the appropriate operating mode, and if the charged device supports such a power and charging mode. It should also be noted that the PPS subprotocol also has been expanded. In particular, a new AVS (Adjustable Voltage Supply) subprotocol, or PD AVS, has been added, which, like PD PPS, allows the device being charged to request a specific voltage setting, but in an additional range: from 15V to 48V with a step of 100mV [5: 68].

The PD protocol, as mentioned earlier, is an intelligent charging protocol that allows you to power and charge devices that can communicate via USB and this protocol. Unfortunately, although this protocol has been around for more than 10 years, it has found its application only in the field of computer gadgets, laptops, monitors and mobile phones. But such categories of electronic devices as Wi-Fi routers, TVs, small household appliances and other devices that do not belong to the IT sphere directly or indirectly have not been equipped with a USB-C port to be able to charge them from your own charger or from a power bank, instead of using a complete power supply that will charge through a “non-intelligent” port/connector.

However, there is a way out of this situation, facilitated by the aforementioned flexibility and universality of the PD protocol. In particular, this refers to a feature of the protocol not mentioned earlier, namely voltage triggering. Although the PD protocol requires a two-way digital “handshake” to establish a correct and safe operating mode – thus requiring a device capable of performing this “handshake”- there is a simplified method of requesting an operating mode from the charger. This involves the use of so-called PD triggers.

A PD trigger is a special microcircuit similar to the one that was introduced in the third revision of the PD and is soldered into the USB-C connector cap, but it operates in a simplified mode. Instead of carrying out a multi-stage process of negotiating the charging mode between the powered device and the charger, the PD trigger, when a cable containing such a “microcircuit” is connected to a charger, simply requests a specific voltage and maximum current. In other words, it tells the charger: “I need a voltage of a certain number of volts and a maximum current of a certain number of amperes.” If the charger supports the requested voltage mode, it will output it to the cable. If not, it will supply only 5 V. By using a cable with a USB-C connector containing a PD trigger for the required voltage on one end and a special “non-intelligent” connector on the other end, it becomes possible to power the equipment you need.

Thus, you have the opportunity to power and charge devices not only from your personal charger but also from a power bank, which allows you to reduce dependence on the availability of electricity in the power grid.

Returning to the main topic, this feature of the PD protocol gives you the opportunity to power some of the things you need, using your power bank, or a charging station that has USB-C ports with the appropriate power, to power devices during planned outages according to schedules and during blackouts. These devices include: the aforementioned Wi-Fi router, which is especially important if you have a non-volatile fiber optic connection; monitors; printers, TVs and other low-power equipment.

You only need to make sure that these devices can be powered using one of the typical fixed voltage modes: 9 V, 12 V, 15 V, or 20 V. In the case of a 5 V PD trigger, power can also be supplied from a USB-A port, which normally outputs 5 V regardless of what is connected to it until another voltage is requested. It is also necessary to ensure that your charger, power bank, or charging station has sufficient power capacity

to support such operation. Otherwise, the situation may become complicated or even lead to device failure, so caution is required.

The USB fast charging protocol Power Delivery is a remarkable technology that has gone through many stages of evolution – from a simple protocol for charging devices from USB-A for a few watts to a protocol that can provide power (under appropriate conditions) to high-power and demanding devices via the USB-C connector. In the case of Ukraine, however, it has also found a special niche, helping people cope with long power outages by enabling the powering of devices that were not originally designed to operate from it. For this reason, it has become a particularly valuable and widely appreciated technology.

#### REFERENCES

1. LIU, Hao, et al. USB powered devices: A survey of side-channel threats and countermeasures. *High-Confidence Computing*, – 2021. p. 12-13.
2. TONG, Zhiguo, et al. A bidirectional USB power delivery voltage-regulating cable. *IEEE Journal of Solid-State Circuits*, – 2025. p. 2866-2878.
3. AUSSERESSE, Pierrick, et al. GaN switches enable high performance architecture for USB-PD EPR Adaptors. In: *PCIM Asia 2023; International Exhibition and Conference for Power Electronics, Intelligent Motion, Renewable Energy and Energy Management*, – 2023, – p. 369-376.
4. MEDINA-GARCIA, Alfredo, et al. Optimum Power Architecture for USB-PD EPR. In: *PCIM Europe 2023; International Exhibition and Conference for Power Electronics, Intelligent Motion, Renewable Energy and Energy Management*, – 2023. p. 1-7.
5. MUKHERJEE, Satyaki; KUMAR, Ashish; MAKSIMOVIĆ, Dragan. Efficiency-optimized current-source resonant converter for USB-C power delivery. In: *2021 IEEE Applied Power Electronics Conference and Exposition (APEC)*, – 2021. p. 500-505.